



**IBT 100 E** 105 qt planetary mixer, stainless steel safety cover, with electronic speed variator (20–215 rpm). Lifting system for Up/Down bowl. Oil-less planetary system. Button control. Equipped with spiral hook, paddle, whisk. Bowl with wheels.

**IBT 100-VEL** 105 qt planetary mixer, stainless steel safety cover, with electronic speed variator (20–215 rpm). Lifting system for Up/Down bowl. Oil-less planetary system. 7" Touchscreen panel for controlling machine. Equipped with spiral hook, paddle, whisk. Bowl with wheels.

**IBT 100-VEL CR** 105 qt planetary mixer, stainless steel safety cover, with electronic speed variator (20–215 rpm). Lifting system for Up/Down bowl. Oil-less planetary system. 7" Touchscreen panel for controlling machine. Equipped with spiral hook, paddle, whisk. Bowl with wheels. AISI 304 Stainless Steel body.

## Specification

Floor model, suitable for all kneading, mixing and whipping operations. Body painted with corrosion resistant electrostatically paint or AISI 304 stainless steel option. Lifting system for Up/Down bowl automatically. Equipped with 105 qt capacity stainless steel AISI 304 bowl. Powerful asynchronous motor with electronical speed variator. Water protected planetary system. Stainless steel bowl guard. Bowl position device allows the mixer to switch on only when the bowl and safety cover are properly positioned together.

## Included Accessories

- 1 x Bowl
- 1 x Spiral Hook
- 1 x Paddle
- 1 x Whisk
- 1 x Scraper



## Main Features

- IBT Series planetary mixers provide very intensive, quick, homogeneous and dead spot free mixing. Professional beater mixer that provides all the basic mixer functions; kneading of all sort of pastes, mixing of semi-liquid products, emulsions and various sauces.
- Dirmak accessories are designed for long-term usage under heavy duty conditions. Mixer is equipped with spiral hook, paddle, wire whisk and mixing bowl for 105 qt.
- Electronic speed variator.
- Button control panel for IBT 100 E
- 7" Touch screen control panel for VEL models
- Scraper equipped
- Maximum capacity 130 lbs for cake doughs.
- Wire safety cover enable to add products while working, thus ensuring operator safety.
- Raising and lowering of the bowl controlled by lifting system with an automatic locking of the bowl when in the raised position.
- Lifting system with motor
- Bowl with wheels
- Safety device will automatically stop the machine when the bowl is lowered.
- Stainless steel bowl guard prevents operation when front portion of guard is out of position.
- Covering the stainless steel wire one, limits the flour and unsafe dust particles when used in bakery and pastry preparation.

## Construction

- Body painted with corrosion resistant electrostatic paint or AISI 304 Stainless steel option.
  - AISI 304 Stainless steel bowl—105 qt capacity.
  - Asynchronous motor with high start-up torque.
  - Water protected planetary system (IP54 electrical controls, IP 32 overall machine)
  - Power : 7,4 + 0,75 HP for IBT 100-VEL
- Planetary movement based on belt driven oil-less planetary system.

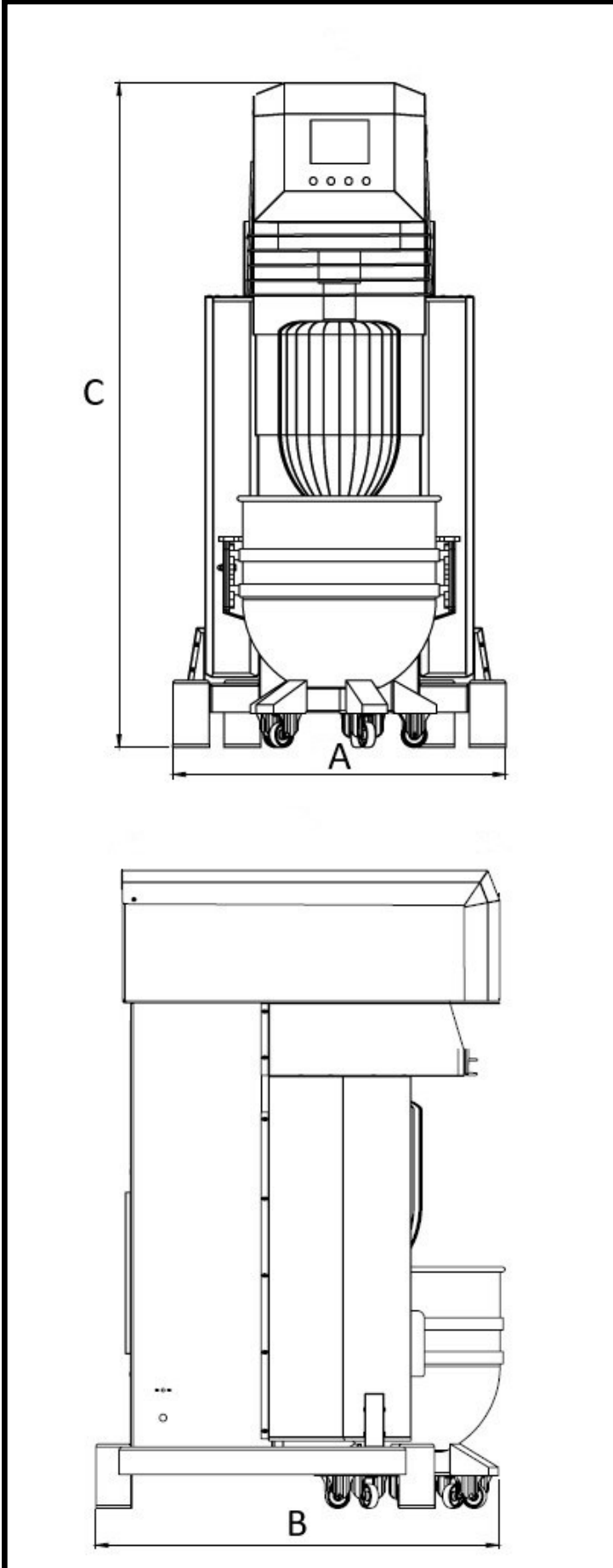

## Electric

### Supply Voltage :

IBT 100-VEL 208-240 V/3P/60 hZ

### Electrical Power Max. :

IBT 100-VEL 7,4 + 0,75 HP

## Capacity

Capacity : 100 L (105 qt)

Cake Dough : 59 Kg (130 lbs)

Egg Whites : 3 L (3,25 qt)

Cookie Dough : 34 Kg (75 lbs)

Bread Dough : 35 Kg (77 lbs)

## Key Information

Width (A) : 960 mm (37,8 in)

Height (B) : 1850 mm (72,8 in)

Depth © : 1200 mm (47,2 in)

Shipping Weight : 650 Kg (1433 lbs)

