



IBT 80-VE

85 qt planetary mixer, stainless steel safety cover, with electronic speed variation (20 –195 rpm). Oil-less planetary system. Equipped with spiral hook, paddle, whisk.

IBT 80-VEL

85 qt planetary mixer, stainless steel safety cover, with electronic speed variation (20 – 195 rpm). Lifting system for Up/Down bowl. Oil-less planetary system. Equipped with spiral hook, paddle, whisk. Bowl with wheels.

IBT 80-VE CR

85 qt planetary mixer, stainless steel safety cover, with electronic speed variation (20 –195 rpm). Oil-less planetary system. Equipped with spiral hook, paddle, whisk. Stainless steel body.

IBT 80-VEL CR

85 qt planetary mixer, stainless steel safety cover, with electronic speed variation (20 –195 rpm). Lifting system for Up/Down bowl. Oil-less planetary system. Equipped with spiral hook, paddle, whisk. Bowl with wheels. Stainless steel body.

Specification

Floor model, suitable for all kneading, mixing and whipping operations. Body painted with corrosion resistant electrostatically paint or AISI 304 stainless steel option. Equipped with 85 qt capacity stainless steel AISI 304 bowl. Powerful asynchronous motor with electronical speed variator. Water protected planetary system. Stainless steel bowl guard. Water proof button control panel with 30 minutes timer. Bowl position device allows the mixer to switch on only when the bowl and safety cover are properly positioned together.

Included Accessories

- 1 x Bowl
- 1 x Spiral Hook
- 1 x Paddle
- 1 x Whisk



Main Features

- IBT Series planetary mixers provide very intensive, quick, homogeneous and dead spot free mixing . Professional beater mixer that provides all the basic mixer functions; kneading of all sort of pastes, mixing of semi-liquid products, emulsions and various sauces.
- Dirmak accessories are designed for long-term usage under heavy duty conditions. Mixer is equipped with spiral hook, paddle, wire whisk and mixing bowl for 85 qt.
- Waterproof button control panel with timer .
- Electronic Speed variator.
- Maximum capacity 100 lbs for cake doughs.
- Wire safety cover enable to add products while working, thus ensuring operator safety.
- Raising and lowering of the bowl controlled by lever with an automatic locking of the bowl when in the raised position.
- Lifting system for IBT 80-VEL model.
- Bowl with wheels for IBT 80-VEL.
- Safety device will automatically stop the machine when the bowl is lowered.
- Stainless steel bowl guard prevents operation when front portion of guard is out of position.
- Covering the stainless steel wire one, limits the flour and unsafe dust particles when used in bakery and pastry preparation.

Construction

- Body painted with corrosion resistant electrostatic paint or AISI 304 Stainless steel option.
- AISI 304 Stainless steel bowl—85 qt capacity.
- Asynchronous motor with high start-up torque.
- Water protected planetary system (IP54 electrical controls, IP 32 overall machine)
- Power :
 - 5,36 HP for IBT 80-VE
 - 5,36 + 0,75 HP for IBT 80-VEL
- Planetary movement based on belt driven oil-less planetary system.

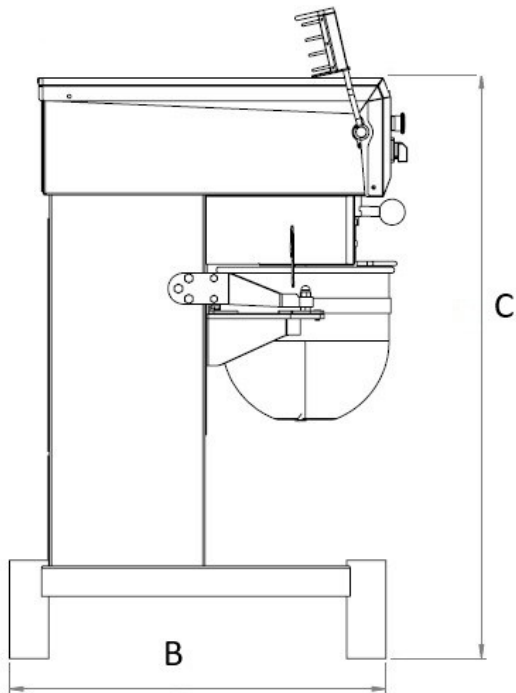
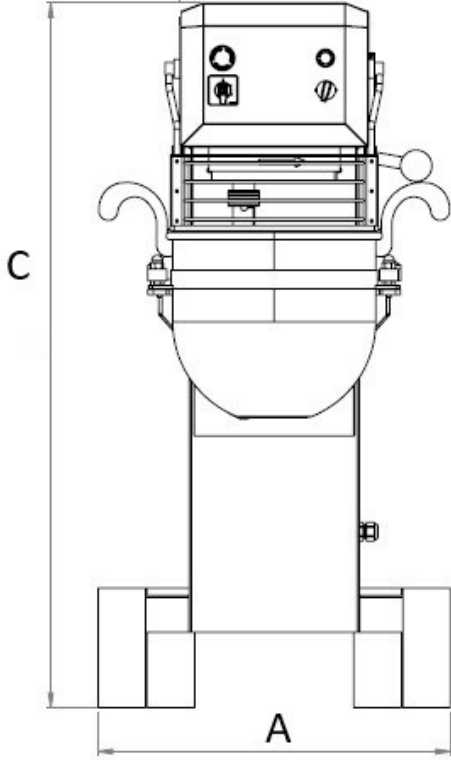

Electric

Supply Voltage :

IBT 80-VE 208-240 V/3P/60 hZ

IBT 80-VEL 208-240 V/3P/60 hZ

Electrical Power Max. :

IBT 80-VE 5,36 HP

IBT 80-VEL 5,36 + 0,75 HP

Capacity

Capacity : 80 L (85 qt)

Cake Dough : 45 Kg (100 lbs)

Egg Whites : 2,2 L (2,3 qt)

Cookie Dough : 28 Kg (60 lbs)

Bread Dough : 25 Kg (54 lbs)

Key Information

Width (A) : 780 mm (30,7 in)

Height (B) : 1450 mm (57,1 in)

Depth (C) : 1100 mm (43,3 in)

Shipping Weight : 320 Kg (705,5 lbs)

