



**ISM 120-32**

126 qt spiral mixer with stainless steel safety guard, dual-speed motor system, maintenance-free transmission, and AISI 304 stainless steel food-contact parts.

**ISM 120-32 CR**

126 qt spiral mixer with stainless steel safety guard, dual-speed motor system, maintenance-free transmission, stainless steel food-contact parts, and stainless steel body.

**ISM 120-32S**

126 qt spiral mixer with stainless steel safety guard, dual-speed motor system, maintenance-free transmission, stainless steel food-contact parts, and reverse bowl operation.

**ISM 120-32S CR**

126 qt spiral mixer with stainless steel safety guard, dual-speed motor system, maintenance-free transmission, stainless steel food-contact parts, reverse bowl operation, and stainless steel body.

**Specification**

ISM Series spiral mixers are designed to provide fast, homogeneous, and efficient mixing performance for professional dough production. The specially engineered spiral mixing system ensures excellent dough development without overheating or overworking the product, resulting in soft, well-aerated dough with consistent texture and easy handling.

The heavy-duty construction is suitable for intensive commercial use in bakeries, pastry kitchens, pizza production, and industrial food applications. AISI 304 stainless steel bowl, spiral arm, and breaker bar provide maximum hygiene, durability, and long service life while ensuring high mixing efficiency and reliable opera-

**Main Features**

- Dirmak equipment is designed for long-term operation under heavy-duty commercial conditions. The mixer is equipped with AISI 304 stainless steel food-contact parts and a 126 qt stainless steel mixing bowl for maximum hygiene, durability, and performance.
- Waterproof button control panel.
- Two speed.
- Two timer.
- Reverse bowl for ISM 120-32S and ISM 120-32S CR
- Strong pulley-belt system.
- Silent operation.
- Maximum (With %60 hydration) 120 lb flour capacity.
- Safety cover in stainless steel.
- Safety device will automatically stop the machine when the cover opens.
- Equipped with wheels and machine levelling feet.



**Construction**

- Body painted with corrosion resistant electrostatic paint or AISI 304 Stainless steel option.
- AISI 304 Stainless steel bowl—126 qt capacity.
- Asynchronous motor with high start-up torque.
- Water protected spiral system (IP54 electrical controls, IP 32 overall machine)
- Power :
 

4,7 - 7,5 HP	ISM 120-32 and ISM 120-32 CR
4,7 - 7,5 + 1,0 HP	ISM 120-32S and ISM 120-32SCR

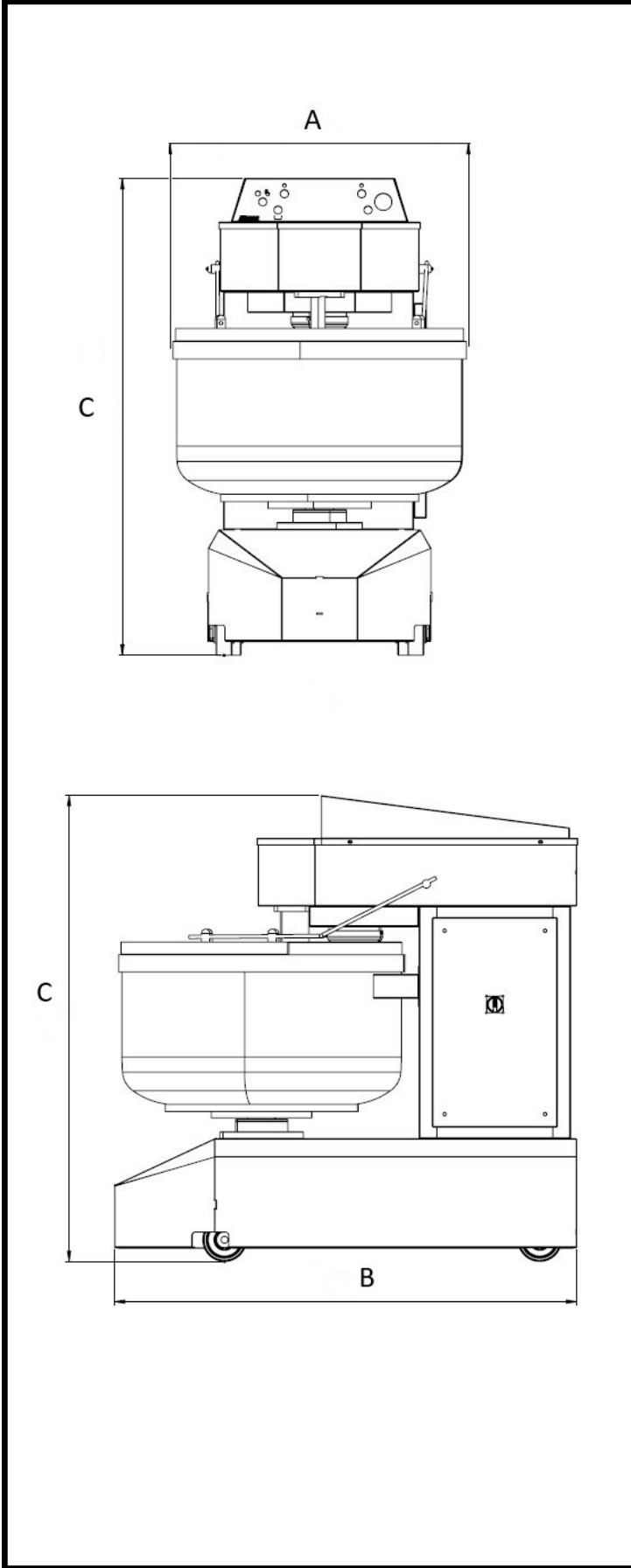

### Electric

#### Supply Voltage :

ISM 120-32 208-240 V/3P/60 hZ

ISM 120-32S 208-240 V/3P/60 hZ

#### Electrical Power Max. :

ISM 120-32 4,7 - 7,5 HP

ISM 120-32S 4,7 - 7,5 + 1,0 HP

### Capacity

Flour : 120 lb / Cycle

Dough : 200 lb / Cycle

Capacity : 120 L 126 qt

Bowl Diameter: 730 mm (28,74 in)

### Key Information

Width (A) : 730 mm (28,74 in)

Depth (B) : 1350 mm (53,15 in)

Height (C) : 1300 mm (51,18 in)

Shipping Weight : 580 Kg (1291 lbs)

