



ISM 250-32S

265 qt spiral mixer with stainless steel safety guard, dual-speed motor system, maintenance-free transmission, stainless steel food-contact parts, and reverse bowl operation.

ISM 250-32S CR

265 qt spiral mixer with stainless steel safety guard, dual-speed motor system, maintenance-free transmission, stainless steel food-contact parts, reverse bowl operation, and stainless steel body.

Specification

ISM Series spiral mixers are designed to provide fast, homogeneous, and efficient mixing performance for professional dough production. The specially engineered spiral mixing system ensures excellent dough development without overheating or overworking the product, resulting in soft, well-aerated dough with consistent texture and easy handling.

The heavy-duty construction is suitable for intensive commercial use in bakeries, pastry kitchens, pizza production, and industrial food applications. AISI 304 stainless steel bowl, spiral arm, and breaker bar provide maximum hygiene, durability, and long service life while ensuring high mixing efficiency and reliable operation.

Main Features

- Dirmak equipment is designed for long-term operation under heavy-duty commercial conditions. The mixer is equipped with AISI 304 stainless steel food-contact parts and a 265 qt stainless steel mixing bowl for maximum hygiene, durability, and performance.
- Waterproof button control panel.
- Two speed.
- Two timer.
- Reverse bowl.
- Strong pulley-belt system.
- Silent operation.
- Maximum (With %60 hydration) 240 lb flour capacity.
- Safety cover in stainless steel.
- Safety device will automatically stop the machine when the cover opens.
- Equipped with wheels and machine levelling feet.



Construction

- Body painted with corrosion resistant electrostatic paint or AISI 304 Stainless steel option.
- AISI 304 Stainless steel bowl—265 qt capacity.
- Asynchronous motor with high start-up torque.
- Water protected spiral system (IP54 electrical controls, IP 32 overall machine)
- Power :
7,5 - 10,0 + 0,75 HP for ISM 250-32S and ISM 250-32S CR

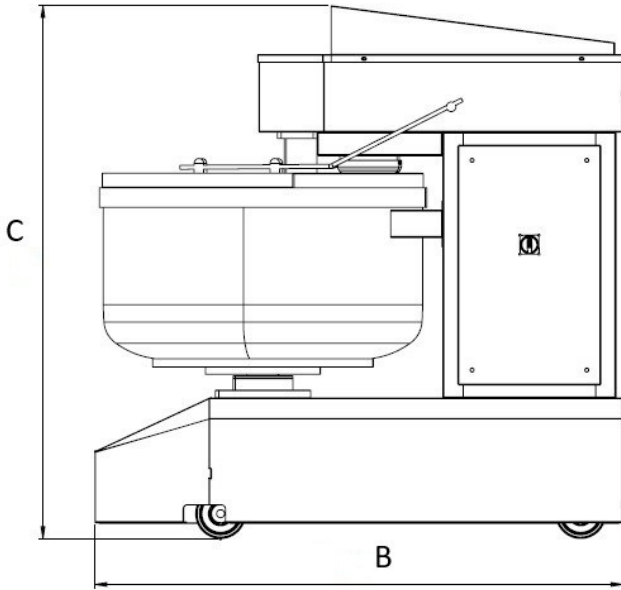
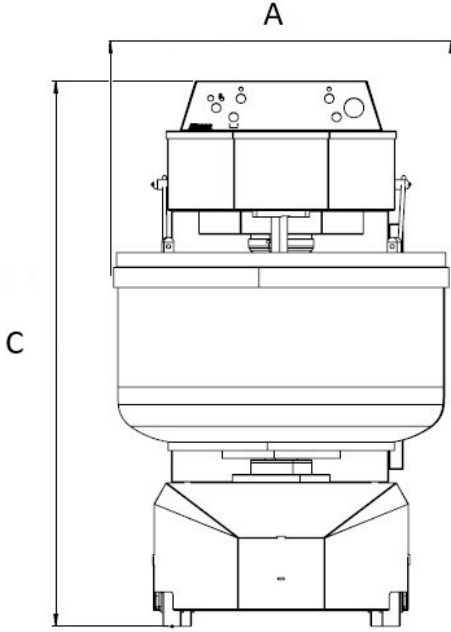

Electric

Supply Voltage :

ISM 250-32S 208-240 V/3P/60 hZ

Electrical Power Max. :

ISM 250-32S 7,5 - 10,0 + 0,75 HP

Capacity

Flour : 240 lb / Cycle

Dough : 330 lb / Cycle

Capacity : 250 L (265 qt)

Bowl Diameter: 900 mm (35,43 in)

Key Information

Width (A) : 950 mm (37,4 in)

Depth (B) : 1500 mm (59,1 in)

Height (C) : 1600 mm (63,1 in)

Shipping Weight : 700 Kg (1543 lbs)

