



**ISM 75-32** 80 qt spiral mixer with stainless steel safety guard, dual-speed motor system, maintenance-free transmission, and AISI 304 stainless steel food-contact parts.

**ISM 75-32 CR** 80 qt spiral mixer with stainless steel safety guard, dual-speed motor system, maintenance-free transmission, stainless steel food-contact parts, and stainless steel body.

**ISM 75-32S** 80 qt spiral mixer with stainless steel safety guard, dual-speed motor system, maintenance-free transmission, stainless steel food-contact parts, and reverse bowl operation.

**ISM 75-32S CR** 80 qt spiral mixer with stainless steel safety guard, dual-speed motor system, maintenance-free transmission, stainless steel food-contact parts, reverse bowl operation, and stainless steel body.

### Main Features

- Dirmak equipments are designed for long-term usage under heavy duty conditions. Mixer is equipped with Stainless steel food contact parts for hygiene and mixing bowl for 80 qt.
- Waterproof button control panel with 60 minute timer .
- Two Speed
- Reverse bowl for ISM 75-32S and ISM 75-32S CR
- Strong pulley-belt system
- Silent operation
- Maximum (with %60 hydration) 75 lb. flour capacity.
- Safety cover in stainless steel.
- Safety device will automatically stop the machine when the cover opens.
- Equipped with wheels and machine levelling feet.



### Specification

ISM Series spiral mixers provide fast, homogeneous, and efficient mixing performance without overheating the dough. The specially designed spiral system ensures soft, well-aerated dough with consistent mixing results. AISI 304 stainless steel bowl, spiral arm, and breaker bar provide maximum hygiene and durability.



### Construction

- Body painted with corrosion resistant electrostatical paint or AISI 304 Stainless steel option.
- AISI 304 Stainless steel bowl—80 qt capacity.
- Asynchronous motor with high start-up torque.
- Water protected spiral system (IP54 electrical controls, IP 32 overall machine)
- Power :  
2,0-3,35 HP for ISM 75-32 and ISM 75-32 CR  
2,0-3,35 + 0,5 HP for ISM 75-32S and ISM 75-32S CR

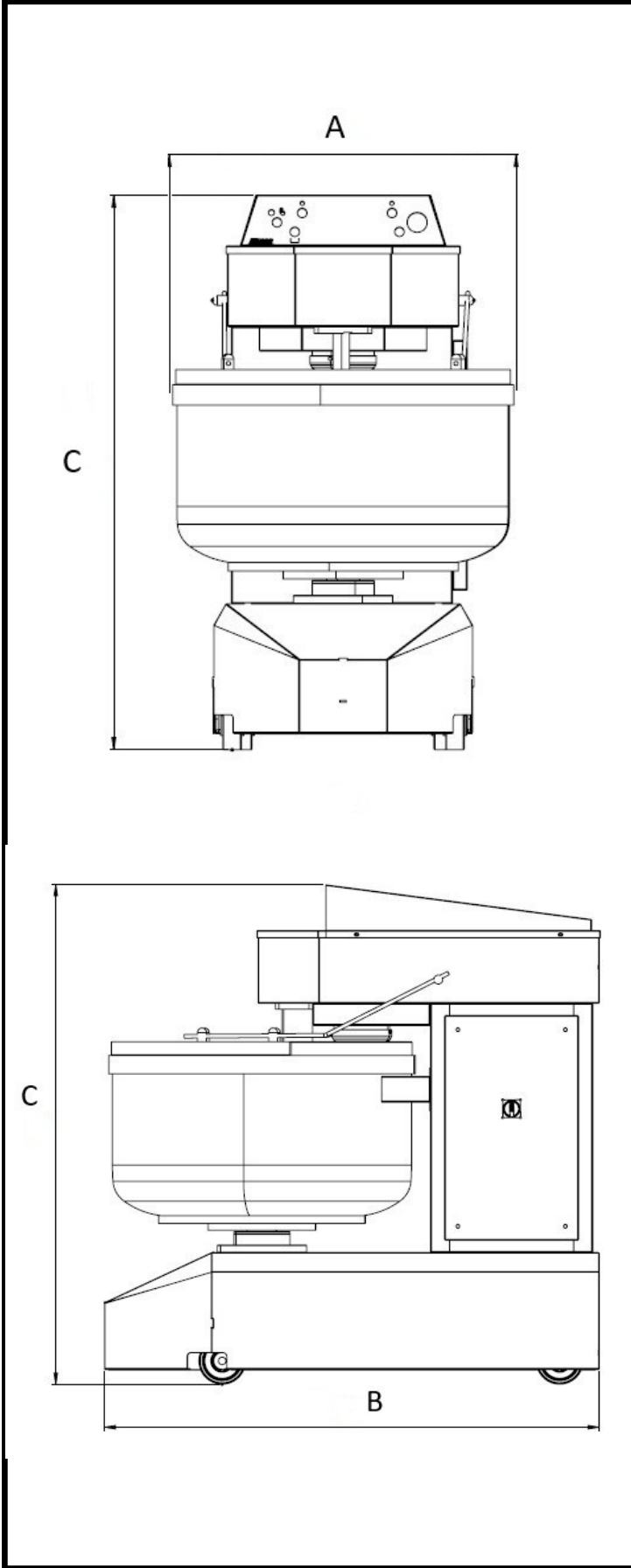

## Electric

### Supply Voltage :

ISM 75-32 208-240 V/3P/60 hZ

ISM 75-32S 208-240 V/3P/60 hZ

### Electrical Power Max. :

ISM 75-32 2,0-3,35 HP

ISM 75-32S 2,0-3,35 + 0,5 HP

## Capacity

Flour : 75 lb. / Cycle

Dough : 115 lb. / Cycle

Capacity : 75 L (80 qt)

Bowl Diameter: 600mm (23.6 in)

## Key Information

Width (A) : 720 mm (28.3 in)

Depth (B) : 1200 mm (47.2 in)

Height (C) : 1200 mm (47.2 in)

Shipping Weight : 350 Kg (722 lbs)

